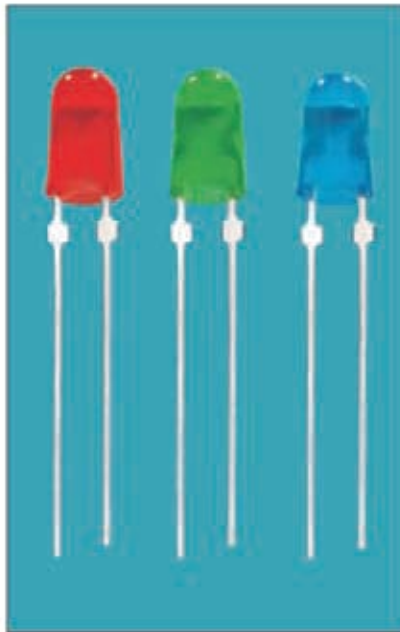
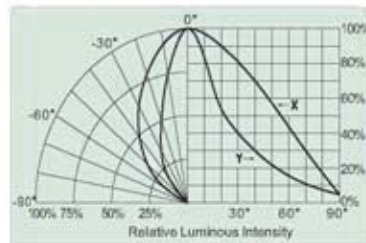
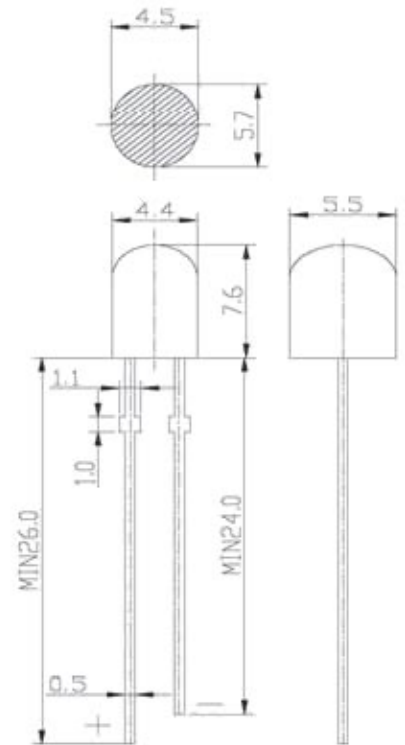

5.7x4.5mm Oval Lamp

Characters

- Viewing angle 40° /70°
- For LED Screen
- UV resistant epoxy

Directive Characteristics

Package Outlines (Unit:mm)

 General Tolerance: ±0.2
 Unless note otherwise

Absolute Maximum Ratings (Ta=25°C)

Parameter	Symbol	Value		Unit
		Green/Blue	Red	
Power Dissipation	P_D	100	125	mW
DC forward Current	I_F	30	50	mA
Pulsed Forward Current	I_{FP}	100	150	mA
Reverse Voltage	V_R	5	5	V
Operating Temperature	T_{opr}	-30~+80		°C
Storage Temperature	T_{stg}	-40~+100		°C

* Duty 1/10 Pulse Width 0.1ms

Electrical Optical Characteristics (Ta=25°C)

Part Number	Material	Chip		Emitted Color	Lens Type	IF(mA)	VF(V)		IV(mcd)	
		Δp (nm)					Min	Max	Min	Max
		Min	Max							
RL52N-UR513/S1	AlGaInP/GaAs	625	635	Ultra Red	Diffused	20	1.7	2.8	400	720
RL52N-GH714D/S1	InGaN/GaN	515	525	Pure Green	Diffused	20	3.0	3.8	1500	2650
RL52N-CB714D/S1	InGaN/GaN	465	475	Blue	Diffused	20	3.0	3.8	350	620

Luminous Intensity Rank

Luminous Intensity(mcd)					
Ultra Red		Pure Green		Blue	
Rank	Data	Rank	Data	Rank	Data
F	400-535	K1	1500-2000	E1	350-460
F1	460-620	L	1750-2300	F	400-535
G	535-720	L1	2000-2650	F1	460-620

Package

 Bulk-----500Pcs/bag
 Taping-----3000Pcs/reel

Precautions in handling

1. When soldering, leave 2.0mm of minimum clearance between the resin and the soldering point.
2. Blue, Green and White products are so sensitive to ESD, that users required to handle with care.

Reliability Test

No	Item	Test Condition	Test Hours/Cycles	Samples Tested	Acc./Rej
1	Room Temperature DC Operating Life	Ta=25°C,IF=20mA	1000 Hrs	76	0/1
2	Thermal Shock	-10°C(5min)→(10sec)→+100°C(5min)	100 Cycles	76	0/1
3	Temperature ycle	-40°C(30min)→(5min)→+85°C(30min)	100 Cycles	76	0/1
4	High Temp./ High Humi. Test	85°C/85%RH	1000 Hrs	76	0/1
5	High Temperature Storage	Ta=100°C	1000 Hrs	76	0/1
6	Low Temperature Storage	Ta= - 40°C	1000 Hrs	76	0/1
7	Soldering Heat	260°C ± 5°C	5 Seconds	76	0/1

Typical Electrical / Optical Characteristics Curves 25°C Ambient Temperature Unless Otherwise Noted)

