



## Specification For Approval

**Customer:** \_\_\_\_\_

**Description:** **LED-LAMP**

**Part number:** **RL50-GH7CB746/I8**

**Date:** **2006-11-28**

**Approved By:**

**Prepared By:**

Approval	Check	Design	Sales
		yu	

EXCEED PERSEVERANCE ELECTRONICS IND CO., LTD

[www.exceedledcn.com](http://www.exceedledcn.com)



**PartNumber: RL50-GH7CB746/I8**

## Features

- 1.Low power consumption.
- 2.High efficiency.
- 3.Versatile mounting on p.c board or panel.
- 4.I.C compatible/ low current requirement.

## ★Package Dimensions

Unit: mm

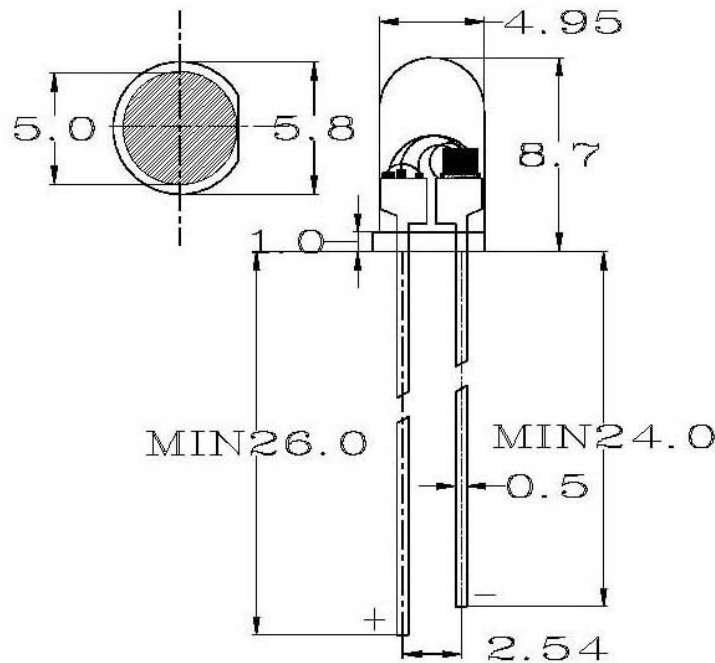

NOTE: TOLERANCE  $\pm 0.2$ mm

## ★ Selection Guide

Part Number	Lens color	Chip		
		Material	Emitted color	$\lambda$ p(nm)
RL50-GH7CB746/I8	Water	InGaN/GaN	BLUE	465
	Clear	InGaN/GaN	GREEN	520



# Light-emitting diode



## TECHNICAL SPECIFICATION

Part Number: RL50-GH7CB746/I8(BLUE)

Parameter	Symbol	MIN.	TYP.	MAX.	UNIT	TEST CONDITION
Forward Voltage	VF	4.0	4.5	5.0	V	If=20mA
Peak Wavelength	$\lambda_p$	465	470	475	nm	
Reverse Current	IR			100	$\mu$ A	VR=5V
Power dissipation	Pd		170		mW	
Luminous Intensity	IV	1000	1500	2000	mcd	If=20mA
Peak Forward Current	If(Peak)			100	mA	
Recommend Forward Current	If(Rec)		30		mA	
Blinking frequency	Fblk		2.8		HZ	VDD=5V
Full Viewing Angle	$2\theta_{1/2}$		30		deg	If=20mA

### NOTE:

1.Luminous intensity is measured with a light sensor and fillister combination that approximates the CIE eye-response curve Tester: EG&G DR-2550.

2.IV classification code is marked on each packing bag. The IV base on line-on's bin classification. The IV guarantee should be add  $\pm 15\%$

3.Absolute maximum ratings: (Ta=25°C)

4.Operating temperature : -40°C TO 80°C

5.Lead soldering: 260°C for 5 seconds



**Part Number: RL50-GH7CB746/I8**

## Blue

Fig1. Forward Current vs Forward Voltage

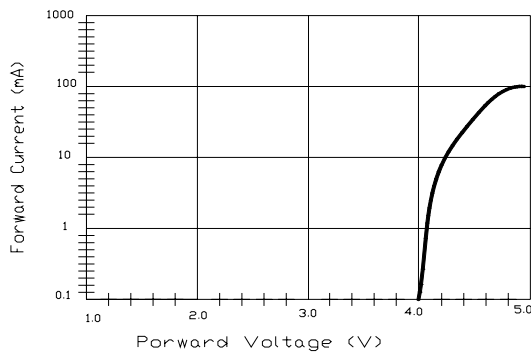

Fig2. Relative Intensity vs Forward Current

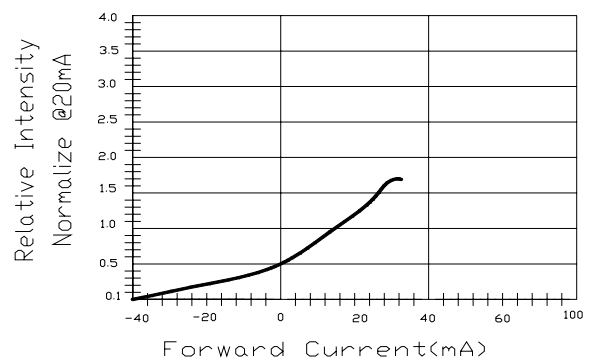

Fig3. Forward Voltage vs Temperature

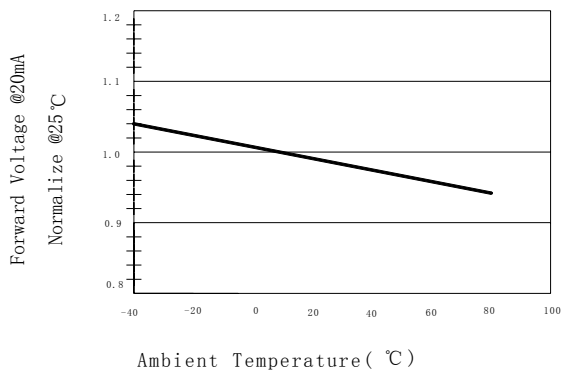

Fig4. Relative Intensity vs Temperature

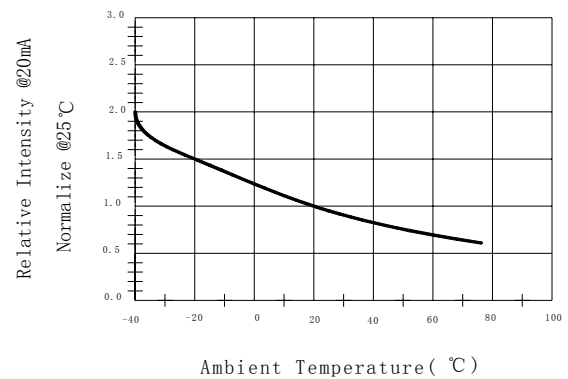

Fig5. Relative Intensity vs Wavelength

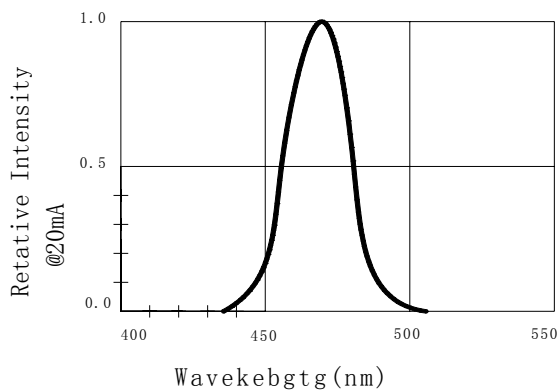
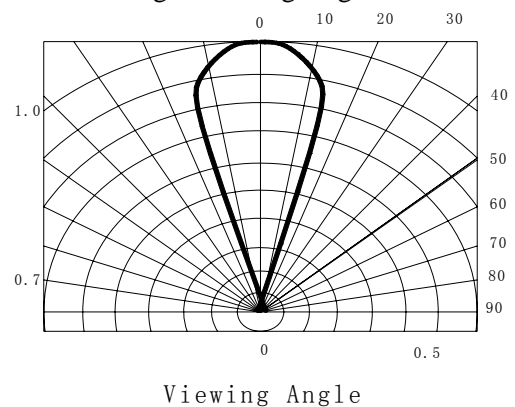

Fig6. Viewing Angle





# Light-emitting diode



## TECHNICAL SPECIFICATION

Part Number: RL50-GH7CB746/I8(PURE GREEN)

Parameter	Symbol	MIN.	TYP.	MAX.	UNIT	TEST CONDITION
Forward Voltage	VF	4.0	4.5	5.0	V	If=20mA
Peak Wavelength	$\lambda_p$	515	520	525	nm	
Reverse Current	IR			40	$\mu$ A	VR=5V
Power dissipation	Pd		170		mW	
Luminous Intensity	IV	5000	6000		mcd	If=20mA
Peak Forward Current	If(Peak)			100	mA	
Recommend Forward Current	If(Rec)		30		mA	
Blinking frequency	Fblk		2.8		HZ	VDD=5V
Full Viewing Angle	$2\theta_{1/2}$		30		deg	If=20mA

### NOTE:

1.Luminous intensity is measured with a light sensor and fillister combination that approximates the CIE eye-response curve Tester: EG&G DR-2550.

2.IV classification code is marked on each packing bag. The IV base on line-on's bin classification. The IV guarantee should be add  $\pm 15\%$

3.Absolute maximum ratings: (Ta=25°C)

4.Operating temperature : -40°C TO 80°C

5.Lead soldering: 260°C for 5 seconds



## Part Number: RL50-GH7CB746/I8

### PURE GREEN

Fig1.Forward Current vs Forward Voltage

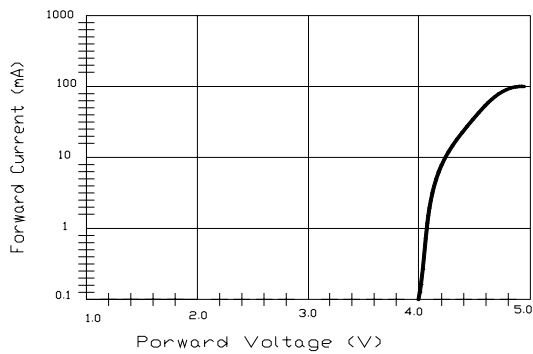

Fig2.Relative Intensity vs Forward Current

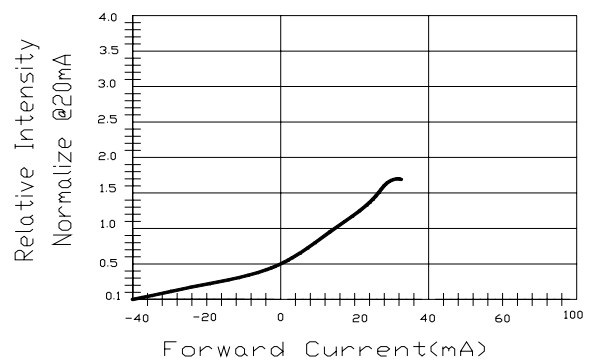

Fig3.Forward Voltage vs Temperature

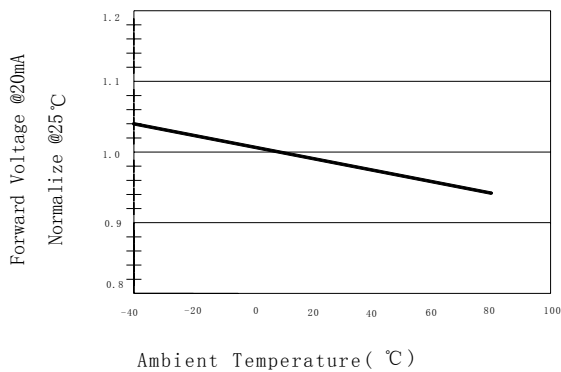

Fig4.Relative Intensity vs Temperature

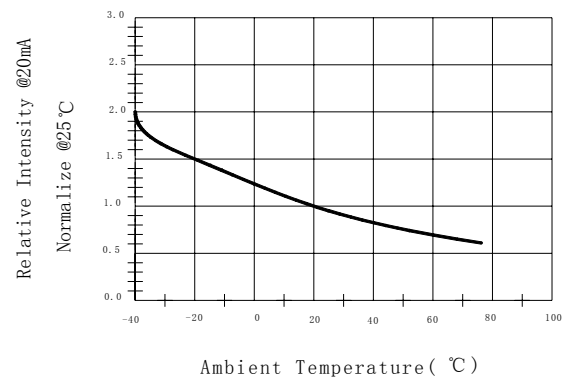

Fig5.Relative Intensity vs Wavelength

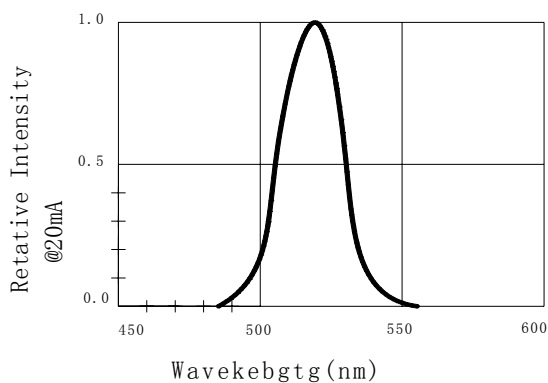

Fig6. Viewing Angle

