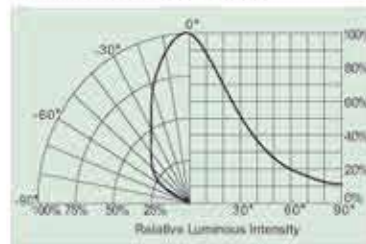
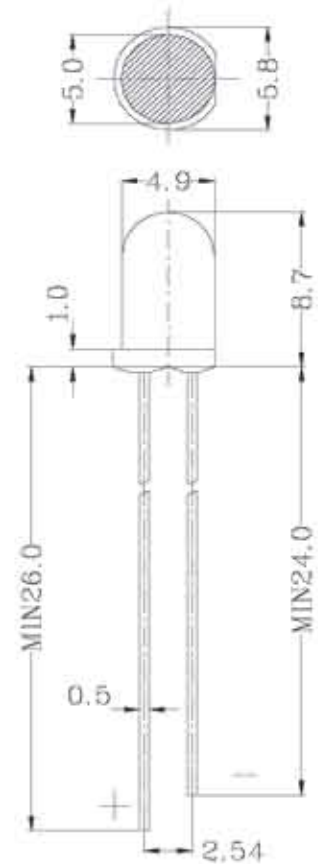

**φ 5.0mm Round Diffused Lamp**

**Characters**

- Viewing angle 60°
- For LED light, indication, illumination
- UV resistant epoxy

**Directive Characteristics**

**Package Outlines (Unit:mm)**

 General Tolerance: ±0.2  
 Unless note otherwise

**Absolute Maximum Ratings (Ta=25°C)**

Parameter	Symbol	Value		Unit
		Green/Blue/White	Red/Orange/Yellow	
Power Dissipation	$P_D$	100	125	mW
DC forward Current	$I_F$	30	50	mA
Pulsed Forward Current	$I_{FV}$	100	150	mA
Reverse Voltage	$V_R$	5	5	V
Operating Temperature	$T_{opr}$	-30~+80		°C
Storage Temperature	$T_{stg}$	-40~+100		°C

\* Duty 1/10 Pulse Width 0.1ms

**Electrical Optical Characteristics (Ta=25°C)**

Part Number	Material	Chip $\lambda_p$ (nm)		Emitted Color	Lens Type	IF(mA)	VF(V)		IV(mcd)	
		Min	Max				Min	Max	Min	Max
RL50-PR533	AlGaInP/GaAs	625	635	Ultra Red	White Diffused	20	1.7	2.8	1000	3000
RL50-UO533	AlGaInP/GaAs	615	625	Ultra Orange	White Diffused	20	1.7	2.8	800	1500
RL50-PY533	InGaAlP/GaAs	585	595	Ultra Yellow	White Diffused	20	1.7	2.8	1000	3000
RL50-GH734D	InGaN/GaN	515	525	Pure Green	White Diffused	20	3.0	3.8	2000	5000
RL50-CB734D	InGaN/GaN	465	475	Blue	White Diffused	20	3.0	3.8	1000	3000
RL50-WH734D	InGaN/GaN	Typical.x=0.3 Typical.y=0.3		White	White Diffused	20	3.0	3.8	2000	6000

\* Luminous intensity rank please see {Standard Bin Grade}

**Precautions in handling**

1. When soldering, leave 2.0mm of minimum clearance between the resin and the soldering point.
2. Blue, Green and White products are so sensitive to ESD, that users required to handle with care.

**Package**

 Bulk-----500Pcs/bag  
 Taping-----2000Pcs/reel

## Reliability Test

No	Item	Test Condition	Test Hours/Cycles	Samples Tested	Acc./Rej
1	Room Temperature DC Operating Life	Ta=25°C,IF=20mA	1000 Hrs	76	0/1
2	Thermal Shock	-10°C(5min)→(10sec)→+100°C(5min)	100 Cycles	76	0/1
3	Temperature ycle	-40°C(30min)→(5min)→+85°C(30min)	100 Cycles	76	0/1
4	High Temp./ High Humi. Test	85°C/85%RH	1000 Hrs	76	0/1
5	High Temperature Storage	Ta=100°C	1000 Hrs	76	0/1
6	Low Temperature Storage	Ta= - 40°C	1000 Hrs	76	0/1
7	Soldering Heat	260°C ± 5°C	5 Seconds	76	0/1

## Typical Electrical / Optical Characteristics Curves 25°C Ambient Temperature Unless Otherwise Noted)

