

Φ 4.0mm Round Water Clear Lamp



Characters

- Viewing angle 30°
- For LED light, indication, illumination
- UV resistant epoxy

Directive Characteristics

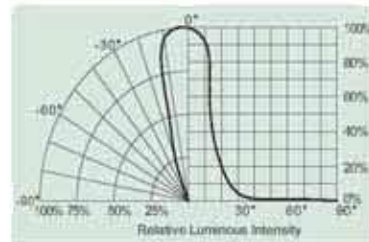

Package Outlines (Unit: mm)

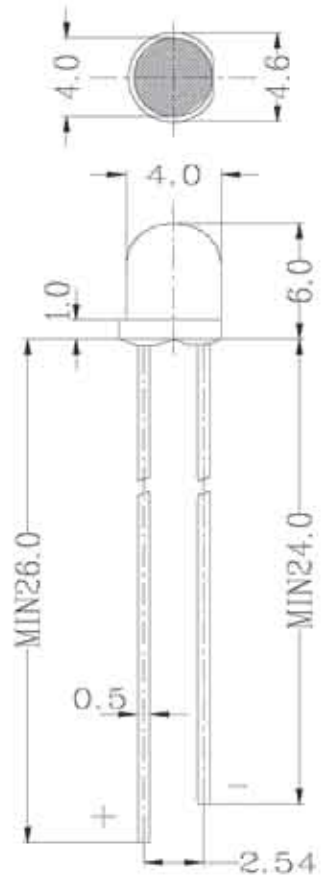

General Tolerance: ±0.2
Unless note otherwise

Absolute Maximum Ratings (Ta=25°C)

Parameter	Symbol	Value		Unit
		Green/Blue/White	Red/Orange/Yellow	
Power Dissipation	P_D	100	125	mW
DC forward Current	I_F	30	50	mA
Pulsed Forward Current	I_{FP}	100	150	mA
Reverse Voltage	V_R	5	5	V
Operating Temperature	T_{opr}	-30~+80		°C
Storage Temperature	T_{stg}	-40~+100		°C

* Duty 1/10 Pulse Width 0.1ms

Electrical Optical Characteristics (Ta=25°C)

Part Number	Material	Chip Δp (nm)		Emitted Color	Lens Type	IF(mA)	VF(V)		IV(mcd)	
		Min	Max				Min	Max	Min	Max
RL35-PR544S	AlGaInP/GaAs	625	635	Ultra Red	Water Clear	20	1.7	2.8	2000	4000
RL35-UO544S	AlGaInP/GaAs	615	625	Ultra Orange	Water Clear	20	1.7	2.8	1200	2500
RL35-PY544S	InGaAlP/GaAs	585	595	Ultra Yellow	Water Clear	20	1.7	2.8	2000	4000
RL35-GH744D	InGaN/GaN	515	525	Pure Green	Water Clear	20	3.0	3.8	3500	5500
RL35-CB744D	InGaN/GaN	465	475	Blue	Water Clear	20	3.0	3.8	2000	3500
RL35-WH744D	InGaN/GaN	Typical.x=0.3 Typical.y=0.3		White	Water Clear	20	3.0	3.8	3500	6500

* Luminous intensity rank please see 《Standard Bin Grade》

Precautions in handling

1. When soldering, leave 2.0mm of minimum clearance between the resin and the soldering point.
2. Blue, Green and White products are so sensitive to ESD, that users required to handle with care.

Package

Bulk-----500Pcs/bag
Taping-----3000Pcs/reel

Reliability Test

No	Item	Test Condition	Test Hours/Cycles	Samples Tested	Acc./Rej
1	Room Temperature DC Operating Life	Ta=25°C,IF=20mA	1000 Hrs	76	0/1
2	Thermal Shock	-10°C(5min)→(10sec)→+100°C(5min)	100 Cycles	76	0/1
3	Temperature ycle	-40°C(30min)→(5min)→+85°C(30min)	100 Cycles	76	0/1
4	High Temp./ High Humi. Test	85°C/85%RH	1000 Hrs	76	0/1
5	High Temperature Storage	Ta=100°C	1000 Hrs	76	0/1
6	Low Temperature Storage	Ta= - 40°C	1000 Hrs	76	0/1
7	Soldering Heat	260°C±5°C	5 Seconds	76	0/1

Typical Electrical / Optical Characteristics Curves
25°C Ambient Temperature Unless Otherwise Noted)

