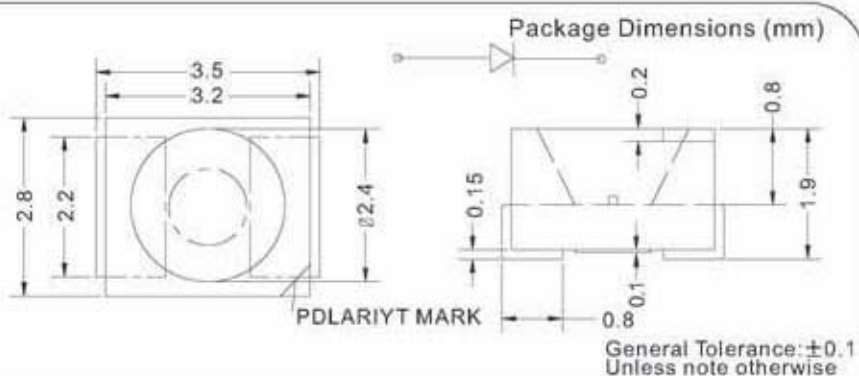
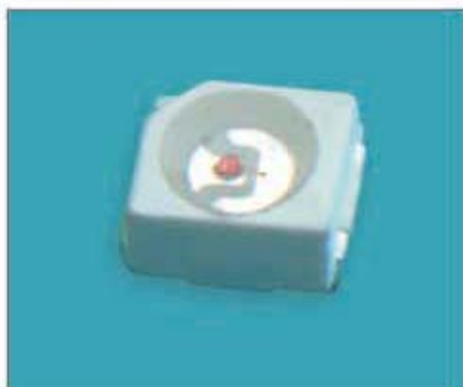

3.5x2.8x1.9 mm (3528)SMD

Part Number	Chip Material	Lens Type	Emitted Color	Forward Voltage (V)		Dominant Wavelength (nm)		Luminous Intensity (mcd)		Reverse Current (uA)	Viewing Angel (deg)
				Min	Max	Min	Max	Min	Max		
RL-S1210SC	GaP	Water Clear	Super Red	1.7	2.8	620	630	100	345	10	120
RL-S1210YC	GaAaP	Water Clear	Super Yellow	1.7	2.8	585	595	125	420	10	120
RL-S1210GC	GaP	Water Clear	Yellow Green	1.7	2.8	565	575	70	125	10	120
RL-S1210BC	GaN	Water Clear	Blue	3.0	3.8	465	475	125	420	10	120
RL-S1210PGC	InGaN	Water Clear	Pure Green	3.0	3.8	515	525	160	600	10	120
RL-S1210WC	InGaN	Water Clear	White	3.0	3.8	Typical.x=0.3 Typical.x=0.3		160	780	10	120

Test condition	IF=20mA	AIF=20mA	AIF=20mA	AVR=5	VIF=20mA
----------------	---------	----------	----------	-------	----------

Absolute Maximum Ratings at Ta=25°C

Parameter	MAX.	Unit
Power Dissipation	100	mW
Peak Forward Current (1/10 Duty Cycle, 0.1ms Pulse Width)	100	mA
Continuous Forward Current	40	mA
Dating Linear From 50°C	0.4	mA/°C
Reverse Voltage	5	V
Operating Temperature Range	-40°C to +80°C	
Storage Temperature Range	-40°C to +80°C	
Lead Soldering Temperature [4mm(.157") From Body]	260°C for 5 Seconds	

FEATURES:

- ◆ Low power consumption
- ◆ Wide viewing angle
- ◆ Ideal for backlight and indicator
- ◆ Various colors and lens types available
- ◆ Package:4000pcs/reel

- Note:**
1. Luminous intensity is measured with a light sensor and filter combination that approximates the CIE eye-response curve.
 2. $\theta_{1/2}$ is the off-axis angle at which the luminous intensity is half the axial luminous intensity.
 3. The dominant wavelength (λ_d) is derived from the CIE chromaticity diagram and represents the single wavelength, which defines the color of the device.

Reliability Test

No	Item	Test Condition	Test Hours/Cycles	Samples Tested	Acc./Rej
1	Room Temperature DC Operating Life	Ta=25°C, IF=20mA	1000 Hrs	76	0/1
2	Thermal Shock	-10°C(5min)→(10sec)→+100°C(5min)	100 Cycles	76	0/1
3	Temperature cycle	-40°C(30min)→(5min)→+85°C(30min)	100 Cycles	76	0/1
4	High Temp./ High Humi. Test	85°C/85%RH	1000 Hrs	76	0/1
5	High Temperature Storage	Ta=100°C	1000 Hrs	76	0/1
6	Low Temperature Storage	Ta= - 40°C	1000 Hrs	76	0/1
7	Soldering Heat	260°C±5°C	5 Seconds	76	0/1

Typical Electrical / Optical Characteristics Curves
 (25°C Ambient Temperature Unless Otherwise Noted)
