



Specification For Approval

Customer: _____

Description: **LED-LAMP**

Part number: **RL-LB5050RGBC-15P-12-S**

Date: **2007-09-26**

Approved By:

Prepared By:

Approval	Check	Design	Sales



Light-emitting diode



Part Number: RL-LB5050RGBC-15P-12-S(RED)

- 504MM*10MM SMD LIGHT BAR (15LEDS)
- PRINTED CIRCUIT BOARD THICKNESS:0.2MM
- LED VIEW ANGLED:100 DEGREE
- PACKAGE:5METERS/REEL

■ Absolute Maximum Rating

Item	Symbol	Absolute Maximum Rating	Unit
Forward Current	I_F	300	mA
Peak Forward Current*	I_{FP}	500	mA
Reverse Voltage	V_R	5	V
Power Dissipation	P_D	7.2	W
Electrostatic discharge	E_{SD}	2000	V
Operation Temperature	T_{opr}	-25~+80	°C
Storage Temperature	T_{stg}	-40~+80	°C
Lead Soldering Temperature*	T_{sol}	Max. 230°C for 5sec Max.	

* I_{FP} Conditions: Pulse Width ≤ 10 msec duty $\leq 1/10$

* T_{sol} Conditions: 3mm from the base of the epoxy bulb

■ Typical Optical/ Electrical Characteristics

Item	Symbol	Condition	Min.	Typ.	Max.	Unit
Forward Voltage	V_F	$I_F=100$ mA		12		V
Luminous Flux	Φ_V	$I_F=100$ mA		10		lm
Peak Wavelength	λ_P	$I_F=100$ mA	621	624		nm
Recommend Forward Current	$I_F(\text{rec})$	--	--	--	300	mA

Notes:

1. Absolute maximum ratings $T_a=25^\circ\text{C}$.
2. Tolerance of measurement of forward voltage ± 0.1 V.
3. Tolerance of measurement of peak Wavelength ± 2.0 nm.
4. Tolerance of measurement of luminous intensity $\pm 15\%$.



Light-emitting diode



Part Number: RL-LB5050RGBC-15P-12-S(GREEN)

■ Absolute Maximum Rating

Item	Symbol	Absolute Maximum Rating	Unit
Forward Current	I_F	300	mA
Peak Forward Current*	I_{FP}	500	mA
Reverse Voltage	V_R	5	V
Power Dissipation	P_D	2.4	W
Electrostatic discharge	E_{SD}	400	V
Operation Temperature	T_{opr}	-25~+80	°C
Storage Temperature	T_{stg}	-40~+80	°C
Lead Soldering Temperature*	T_{sol}	Max. 230°C for 5sec Max.	

* I_{FP} Conditions: Pulse Width ≤ 10 msec duty $\leq 1/10$

* T_{sol} Conditions: 3mm from the base of the epoxy bulb

■ Typical Optical/ Electrical Characteristics

Item	Symbol	Condition	Min.	Typ.	Max.	Unit
Forward Voltage	V_F	$I_F=100$ mA		12		V
Luminous Flux	Φ_V	$I_F=100$ mA		35		lm
Peak Wavelength	λ_P	$I_F=100$ mA	516	518		nm
Recommend Forward Current	$I_F(\text{rec})$	--	--	--	300	mA

Notes:

1. Absolute maximum ratings $T_a=25^\circ\text{C}$.
2. Tolerance of measurement of forward voltage ± 0.1 V.
3. Tolerance of measurement of peak Wavelength ± 2.0 nm.
4. Tolerance of measurement of luminous intensity $\pm 15\%$.



Light-emitting diode



Part Number: RL-LB5050RGBC-15P-12-S(BLUE)

■ Absolute Maximum Rating

Item	Symbol	Absolute Maximum Rating	Unit
Forward Current	I_F	300	mA
Peak Forward Current*	I_{FP}	500	mA
Reverse Voltage	V_R	5	V
Power Dissipation	P_D	2.4	W
Electrostatic discharge	E_{SD}	400	V
Operation Temperature	T_{opr}	-25~+80	°C
Storage Temperature	T_{stg}	-40~+80	°C
Lead Soldering Temperature*	T_{sol}	Max. 230°C for 5sec Max.	

* I_{FP} Conditions: Pulse Width ≤ 10 msec duty $\leq 1/10$

* T_{sol} Conditions: 3mm from the base of the epoxy bulb

■ Typical Optical/ Electrical Characteristics

Item	Symbol	Condition	Min.	Typ.	Max.	Unit
Forward Voltage	V_F	$I_F=100$ mA		12		V
Luminous Flux	Φ_V	$I_F=100$ mA		10		lm
Peak Wavelength	λ_P	$I_F=100$ mA	469	471		nm
Recommend Forward Current	$I_F(\text{rec})$	--	--	--	300	mA

Notes:

1. Absolute maximum ratings $T_a=25^\circ\text{C}$.
2. Tolerance of measurement of forward voltage ± 0.1 V.
3. Tolerance of measurement of peak Wavelength ± 2.0 nm.
4. Tolerance of measurement of luminous intensity $\pm 15\%$.



Part Number: RL-LB5050RGBC-150P-12-S

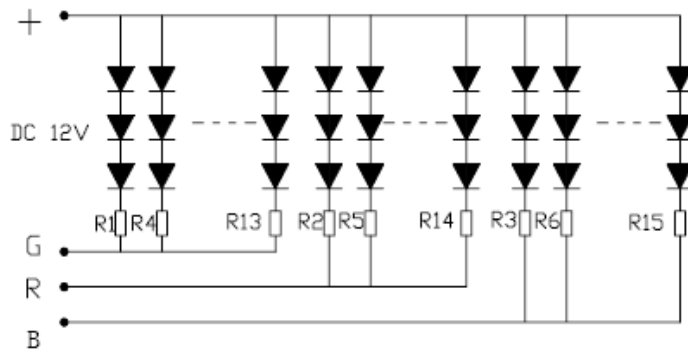
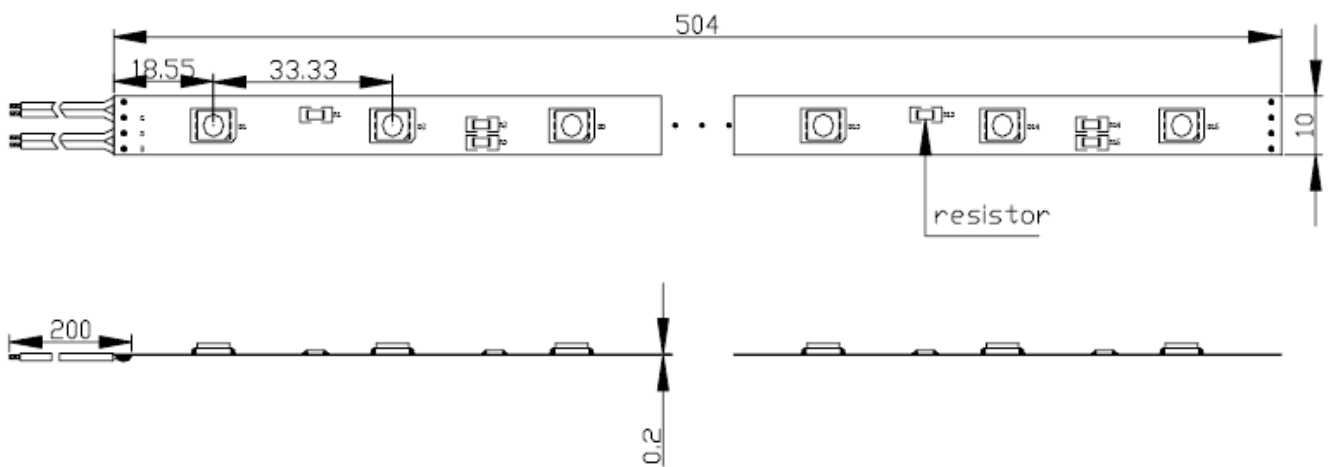

Notes:

1. All dimension units are millimeters.
2. All dimension tolerance is $\pm 0.2\text{mm}$ unless otherwise noted.
3. An epoxy meniscus may extend about 1.5mm down the leads.

Burr around bottom of epoxy may be 0.5mm max..